

# HILTI

# TE 905-AVR

Operating instructions

en

Mode d'emploi

fr

Manual de instrucciones

es

Manual de instruções

pt



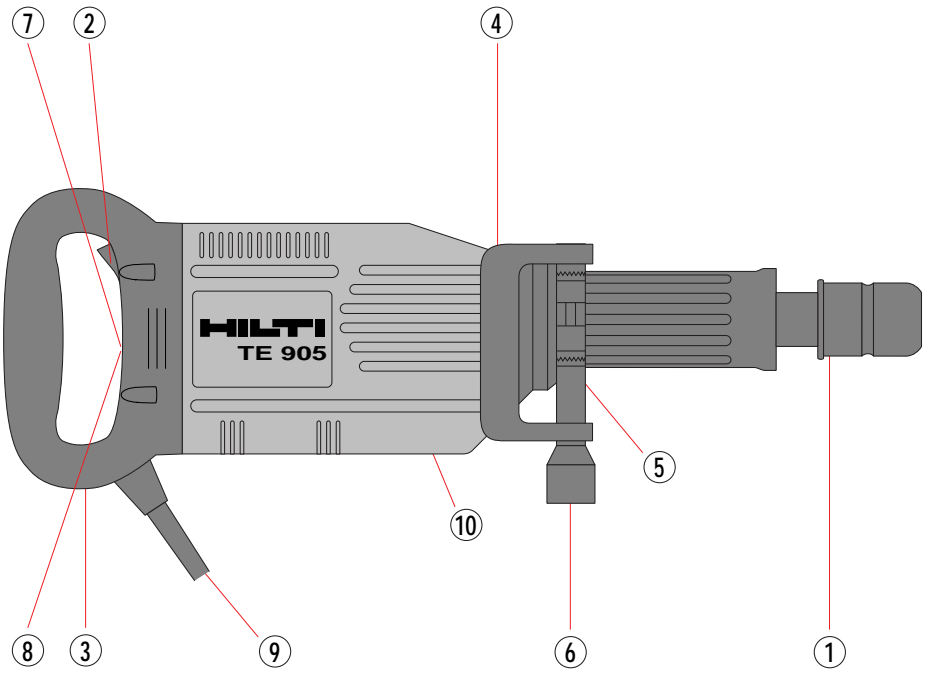

UL listed to US and Canadian safety standards  
Homologué UL (conforme aux normes de sécurité américaines et canadiennes)  
Producto homologado según normas de seguridad americanas y canadienses  
Produto homologado de acordo com as normas de segurança americanas e canadianas



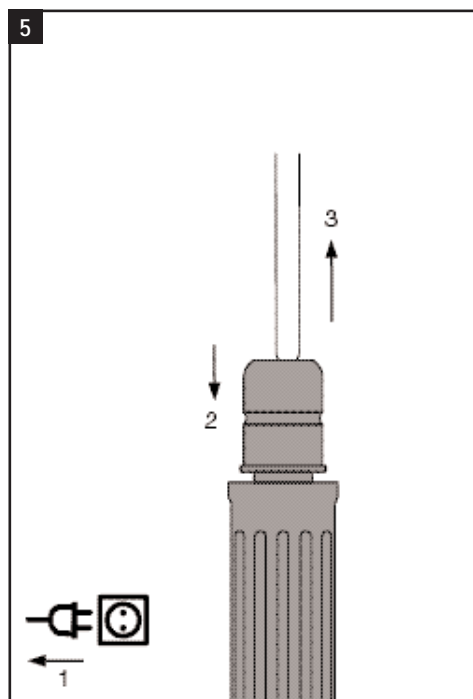
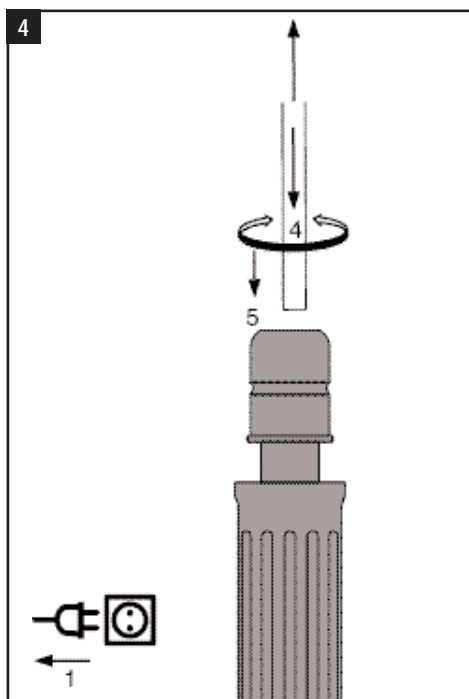
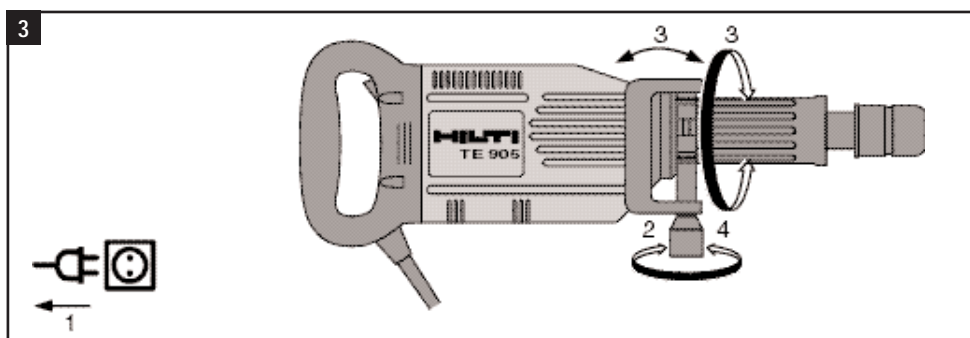
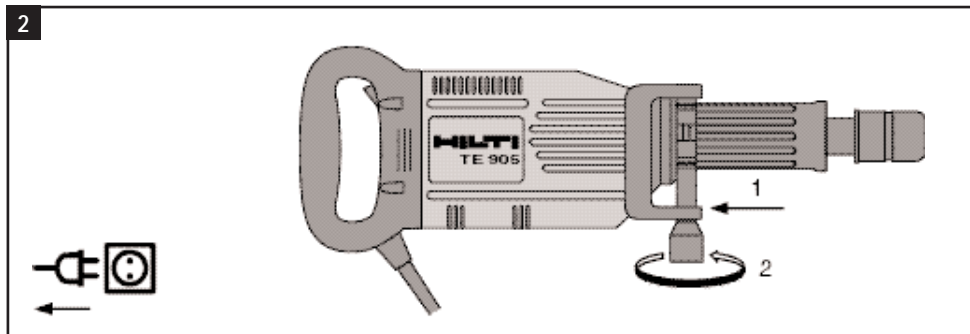

# TE 905-AVR breaker

*It is essential that the operating instructions are read before the tool is operated for the first time.*

*Always keep these operating instructions together with the tool.*

*Ensure that the operating instructions are with the tool when it is given to other persons.*

## Operating controls and components 1

- ① Chuck
- ② On/off switch
- ③ Grip
- ④ Side handle
- ⑤ Side handle clamp
- ⑥ Screw
- ⑦ Service indicator
- ⑧ Activation indicator (theft protection system) (available as option)
- ⑨ Supply cord
- ⑩ Ventilation slots

Contents	Page
1. General information	1
2. General safety rules	2
3. Specific safety rules and symbols	3
4. Functional description	3
5. Assembly	4
6. Operation	5
7. Care and maintenance	6
8. Tools and accessories	7
9. Troubleshooting	7
10. Disposal	8
11. Warranty	8

## 1. General information

### 1.1 Signal words and their meaning

#### -CAUTION-

Used to draw attention to a potentially dangerous situation which could lead to minor personal injury or damage to the equipment or other property.

#### -NOTE-

Used to draw attention to an instruction or other useful information.

### 1.2 Pictograms

#### Warning signs



General warning



Warning: electricity



Warning: hot surface

#### Obligation signs



Wear a safety helmet



Wear eye protection



Wear breathing protection



Wear ear protection



Wear protective gloves

#### Symbols



Read the operating instructions before use.



Equipped with theft protection system

**1** These numbers refer to the corresponding illustrations. The illustrations can be found on the fold-out cover pages. Keep these pages open while studying the operating instructions.

In these operating instructions, the TE 905-AVR breaker is referred to as "the tool".

#### Location of identification data on the tool

The type designation can be found on the rating plate and the serial number on the side of the motor housing. Make a note of this data in your operating instructions and always refer to it when making an enquiry to your Hilti representative or service department.

Type: TE 905-AVR

Serial no.:

## 2. General safety rules

### 1. WARNING!

Read and understand all instructions.

Failure to follow all instructions listed below may result in electric shock, fire and/or serious personal injury.

**SAVE THESE INSTRUCTIONS**

### 2. Work Area

Keep your work area clean and well lit. Cluttered benches and dark areas invite accidents.

Do not operate power tools in explosive atmospheres, such as in the presence of flammable liquids, gases, or dust. Power tools create sparks which may ignite the dust or fumes.

Keep bystanders, children and visitors away while operating a power tool. Distractions can cause you to lose control.

### 3. Electrical Safety

Grounded tools must be plugged into an outlet properly installed and grounded in accordance with all codes and ordinances. Never remove the grounding prong or modify the plug in any way. Do not use any adaptor plugs. Check with a qualified electrician if you are in doubt as to whether the outlet is properly grounded. If the tools should electrically malfunction or break down, grounding provides a low resistance path to carry electricity away from the user.

Applicable only to Class I (grounded) tools.

Avoid body contact with grounded surfaces such as pipes, radiators, ranges and refrigerators. There is an increased risk of electric shock if your body is grounded.

Don't expose power tools to rain or wet conditions. Water entering a power tool will increase the risk of electric shock.

Do not abuse the cord. Never use the cord to carry the tools or pull the plug from an outlet. Keep cord away from heat, oil, sharp edges or moving parts. Replace damaged cords immediately. Damaged cords increase the risk of electric shock.

When operating a power tool outside, use an outdoor extension cord marked «W-A» or «W». These cords are rated for outdoor use and reduce the risk of electric shock.

### 4. Personal Safety

Stay alert, watch what you are doing and use common sense when operating a power tool. Do not use a tool while tired or under the influence of drugs, alcohol, or medication. A moment of inattention while operating power tools may result in serious personal injury.

Dress properly. Do not wear loose clothing or jewelry. Contain long hair. Keep your hair, clothing,

and gloves away from moving parts. Loose clothes, jewelry, or long hair can be caught in moving parts.

Avoid accidental starting. Be sure switch is off before plugging in. Carrying tools with your finger on the switch or plugging in tools that have the switch on invites accidents.

Remove adjusting keys or wrenches before turning the tool on. A wrench or a key that is left attached to a rotating part of the tool may result in personal injury.

Do not overreach. Keep proper footing and balance at all times. Proper footing and balance enables better control of the tool in unexpected situations.



Use safety equipment. Always wear eye protection. Dust mask, non-skid safety shoes, hard hat, or hearing protection must be used for appropriate conditions.

### 5. Tool Use and Care

Use clamps or other practical way to secure and support the workpiece to a stable platform. Holding the work by hand or against your body is unstable and may lead to loss of control.

Do not force tool. Use the correct tool for your application. The correct tool will do the job better and safer at the rate for which it is designed.

Do not use tool if the switch does not turn it on or off. Any tool that cannot be controlled with the switch is dangerous and must be repaired.

Disconnect the plug from the power source before making any adjustments, changing accessories, or storing the tool. Such preventive safety measures reduce the risk of starting the tool accidentally.

Store idle tools out of reach of children and other untrained persons. Tools are dangerous in the hands of untrained users.

Maintain tools with care. Keep cutting tools sharp and clean. Properly maintained tools with sharp cutting edges are less likely to bind and are easier to control.

Check for misalignment or binding of moving parts, breakage of parts and any other condition that may affect the tools operation. If damaged, have the tool serviced before using. Many accidents are caused by poorly maintained tools.

Use only accessories that are recommended by the manufacturer for your model. Accessories that may be suitable for one tool may become hazardous when used on another tool.

## 6. Service

Tool service must be performed only by qualified repair personnel. Service or maintenance performed by unqualified personnel could result in a risk of injury.

When servicing a tool, use only identical replacement parts. Follow instructions in the Maintenance section of this manual. Use of unauthorized parts or failure to follow Maintenance Instructions may create a risk of electric shock or injury.

## 3. Specific safety rules and symbols

Hold tools by insulated gripping surfaces when performing an operation where the cutting tool may contact hidden wiring or its own cord. Contact with a "live" wire will make exposed metal parts of the tool "live" and shock the operator.

Wear ear protectors when using the tool for extended periods. Prolonged exposure to high intensity noise can cause hearing loss.

### Personal protective equipment

The user and any other persons in the vicinity must wear suitable eye protection, a safety helmet, ear protection, protective gloves and breathing protection.



Wear a safety helmet



Wear eye protection



Wear breathing protection



Wear ear protection



Wear protective gloves

### Symbols used on the tool:

V	volts	A	amperes
W	watts	$n_0$	no load speed
~	alternating current	/min	revolutions per minute
Hz	hertz	∅	diameter

## 4. Functional description

The TE 905-AVR is a heavy-duty breaker. It is equipped with a TE-S chuck. The tool features an active vibration reduction system that reduces vibration by about 50%.

The tool can be equipped with an optional theft protection function. This function operates on a radio / transponder principle. When equipped with this function, the tool can be activated and operated only by authorized users.

### Correct use

The TE 905-AVR is a hand-held electric tool for chiseling. The tool is suitable for chiseling and demolition work on concrete, masonry, stone or asphalt. The working environment may be on a construction site of any kind. The tool may be operated only when supplied with a voltage in compliance with the information given on its rating plate.

### Chucks:

- TE-S chucks

### Switches:

- On/off switch

### Grips:

- Adjustable vibration-absorbing side handle.
- Vibration-absorbing grip.

### Lubrication:

- Permanent lubrication.

### Indicator lamps:

- Service indicator (red).
- Theft protection system indicator (available as option) (blinks yellow).

### The following items are supplied as standard:

- Tool
- Grease dispenser (50 ml)
- Operating instructions
- Toolbox
- Cleaning cloth

See figure 1 and the explanations of operating controls and components on page 1.

## Technical data

<b>Tool</b>	<b>TE 905-AVR</b>
Rated voltage	120 V
Rated current input	15 A
Mains frequency	50–60 Hz
Weight of tool	11.3 kg (2.5 lbs)
Dimensions (l×w×h)	680×110×240 mm (26.8×4.3×9.4 in)
Chuck	TE-S
Hammering speed under load	2200 blows/min
Single impact energy	20 joules
Chiseling performance in medium-hard concrete	1300 cm <sup>3</sup> /min (79.3 in <sup>3</sup> /min)
Permanent lubrication	
Adjustable side handle	
Foam rubber padded grip and side handle	
Electronic speed (r.p.m.) limitation	
On/off switch	
Vibration reduction with built in AVR-system	
Service indicator	
Right of technical changes reserved	

## 5. Assembly



Ensure that the tool is disconnected from the mains supply.

### 5.1 Use of extension cords

Use only extension cords of a type approved for the application and with conductors of adequate cross section. Recommended minimum conductor cross section and max. cable lengths:

Mains voltage	Conductor cross section				AWG	
	1.5 mm <sup>2</sup>	2.0 mm <sup>2</sup>	2.5 mm <sup>2</sup>	3.5 mm <sup>2</sup>	14	12
100 V	–	20 m	–	30 m	–	–
110–120 V	20 m	25 m	30 m	–	75 ft	125 ft
220–240 V	50 m	–	100 m	–	–	–

Do not use extension cords with 1.25 mm<sup>2</sup> or 16 AWG conductor cross sections.

### 5.2 Use of a generator or transformer

This tool may be powered by a generator or transformer which fulfils the following conditions:

- AC voltage output, power output at least 2600 W
  - The operating voltage must be within +5% and –15% of the rated voltage at all times.
  - Frequency range 50–60 Hz, never above 65 Hz
  - Automatic voltage regulation with starting boost
- Never operate other tools or appliances from the generator or transformer at the same time. Switching other tools or appliances on and off may cause undervoltage and / or overvoltage peaks, resulting in damage to the tool.

### 5.3 Fitting the side handle **2**

1. Fit the side handle and side handle clamp onto the tool.
2. Secure the side handle by tightening the screw knob.

## 6. Operation



Never use the tool without the side handle.  
Use a vice or clamp to secure loose workpieces.

	<b>-CAUTION-</b>
	<ul style="list-style-type: none"> <li>● The insert tool may become hot during use.</li> <li>● There is a risk of burning the hands.</li> <li>● Wear protective gloves when changing insert tools.</li> </ul>

### 6.1 Adjusting the side handle 3

1. Unplug the supply cord from the mains socket.
2. Slacken the screw knob on the side handle.
3. Bring the side handle into the desired position.
4. Tighten the screw knob to secure the side handle in the desired position.

### 6.2 Fitting the insert tool 4

#### -NOTE-

The chisel can be locked in the chuck in 6 different positions (in 60° increments).

Flat and shaped chisels can thus always be brought into the optimum position for the job on hand.

1. Unplug the supply cord from the mains socket.
2. Check that the insert tool connection end is clean and lightly greased. Clean and grease the connection end if necessary.
3. Check that the sealing lip on the dust cap is clean and in good condition. Clean the dust cap if necessary or replace it if the sealing lip is damaged.
4. Push the insert tool into the chuck and rotate it while applying light pressure until it engages in the guide grooves.
5. Push the insert tool into the chuck until it is heard to engage.
6. Check that the insert tool is held securely by attempting to pull it out of the chuck.

### 6.3 Removing the insert tool 5

1. Unplug the supply cord from the mains socket.
2. Open the chuck by pulling back the locking sleeve.
3. Pull the insert tool out of the chuck.

### 6.4 Chiseling

#### -NOTE-

When working at low temperatures: The hammering mechanism works only when the tool has reached a minimum operating temperature. Bring the drill bit into contact with the base material and allow the tool to run under no load until the minimum operating temperature is reached. If necessary, repeat this procedure until the hammering mechanism begins to operate.



#### -CAUTION-

- Drilling may cause splintering of the material.
- Splinters may cause injury to parts of the body and eyes.
- Wear eye protection, protective gloves and breathing protection if no dust removal system is used.



#### -CAUTION-

- The tool and the drilling operation emit noise.
- Excessive noise may damage the hearing.
- Wear ear protection.

### 6.4.1 Switching on

1. Plug the supply cord into the electric socket.
2. Press the on/off switch.

### 6.4.2 Switching off

Press the on/off switch.

### 6.4.3 Chiseling tips

#### Reinforcing bars

Always guide the chisel toward the edge of the material and not toward the reinforcing bar.

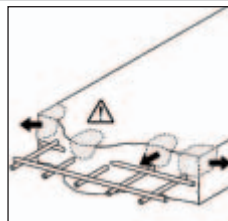

#### Starting chiseling

Position the point of the chisel approx. 80–100 mm (3.1–3.9 in) from the edge of the material.

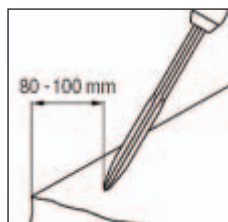

#### Chiseling direction

Begin chiseling at an angle of 70–80° to the concrete surface, with the tip of the chisel pointing toward the edge. Increase the angle to 90° as the chisel penetrates, thus breaking away material.

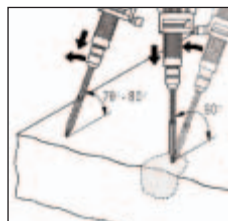

**Self-sharpening process**

Rotate the chisel in the chuck at regular intervals (ensures even wear and assists the self-sharpening process).

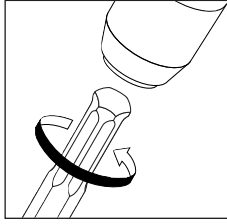
**Depth of penetration**

Polygon chisels break up and crush the material even at considerable depth.

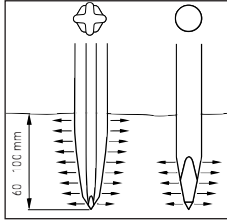
**Contact pressure**

Contact pressure too low:  
Chisel jumps about.  
Contact pressure too high:  
Lower chiseling performance.

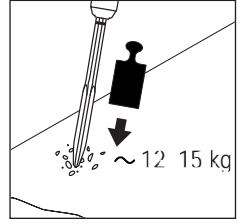

## 7. Care and maintenance

Unplug the supply cord from the mains socket.

**7.1 Care of insert tools**

Clean off dirt and dust deposits and protect your insert tools from corrosion by wiping them from time to time with an oil-soaked rag.

**7.1.1 Regrinding insert tools**

Pointed, flat and wide-flat chisels can be reground when slightly worn at the tip or cutting edge.

**-NOTE-**

Avoid overheating the surface of the chisel during grinding (no discoloration).

**7.2 Care of the electric tool**

The outer casing of the tool is made from impact-resistant plastic. Sections of the grip are made from an elastomer material.

Never operate the tool when the ventilation slots are blocked. Clean the ventilation slots carefully using a dry brush. Do not permit foreign objects to enter the interior of the tool. Clean the outside of the tool at regular intervals using a slightly damp cloth. Do not use a spray, steam pressure cleaning equipment or running water for cleaning. This may negatively affect the electrical safety of the tool. Always keep the grip surfaces of the tool free from oil and grease. Do not use cleaning agents which contain silicone.

**7.3 Service indicator **

The tool is equipped with a service indicator.

**7.3.1 The service indicator lights**

The carbon brushes have reached the end of their life. The tool can be operated for a further approx. ten hours after the service indicator lights, after which the automatic cut-out will be activated. Please return the tool to a Hilti service center in good time so that it is ready for use when required.

**7.3.2 The service indicator blinks**

An electrical fault has occurred. The tool has been rendered inoperable and should be returned to a Hilti repair center for servicing.

**7.4 Maintenance**

Check all external parts of the tool for damage at regular intervals and check that all controls operate faultlessly. Do not operate the tool if parts are damaged or when the controls do not function faultlessly. If necessary, your electric tool should be repaired at a Hilti repair center. Repairs to the electrical section of the tool may be carried out only by trained electrical specialists.

**7.5 Checks after care and maintenance**

After carrying out care and maintenance on the tool, check that all protective equipment has been refitted and that all items function faultlessly.

## 8. Tools and accessories

<b>TE 905-AVR</b>	
TE-S chuck	●
Pointed chisel	
Flat chisel	
Wide flat chisel	
Asphalt chisel	
Flexible chisel	
Bushing tool	
Tamping tool	
Earth rod rammer	
HSS hanging support system	●
TPS = theft protection system with	
TPS-K activation key	●

## 9. Troubleshooting

Fault	Possible cause	Remedy
The tool doesn't start	Fault in mains supply	Plug in another electric appliance and check whether it works
	Supply cord or plug defective	The cord should be checked and, if necessary, replaced by an electrical specialist
	On/off switch defective	The cord should be checked and, if necessary, replaced by an electrical specialist
No hammering action	The tool is too cold	Allow the tool to warm up to the minimum operating temperature (see 6.4 "Chiseling")
The tool does not achieve full power	Extension cord with inadequate cross section used	Use an extension cord with adequate cross section (see 5.1 "Use of extension cords")

## 10. Disposal

Most of the materials from which Hilti electric tools are manufactured can be recycled. The materials must be correctly separated before they can be recycled. In many countries, Hilti has already made arrangements for taking back your old electric tools for recycling. Please ask your Hilti customer service department or Hilti representative for further information.

Should you wish to return the electric tool yourself to a disposal facility for recycling, proceed as follows:

Dismantle the electric tool as far as possible without the need for special tools. Use absorbent paper to wipe oily parts clean and to collect any grease that runs out (total quantity approx. 50 ml). This paper should also be disposed of correctly. **On no account should oil or grease be allowed to enter the waste water system or to find its way into the ground.**

The individual parts should be separated as follows:

Part / assembly	Main material	Recycling
Toolbox	Plastic	Plastics recycling
Gear housing	Plastic with magnesium alloy / brass parts	Scrap metal
Bearing plate	Magnesium alloy / brass	Scrap metal
Grip, side handle	Plastic	Plastics recycling
Motor housing	Plastic	Plastics recycling
Fan	Plastic	Plastics recycling
Motor (rotor and stator)	Steel and copper	Scrap metal
Supply cord	Copper, elastomer	Scrap metal
Hammering mechanism parts	Steel	Scrap metal
Screws, small parts	Steel	Scrap metal

## 11. Warranty

Hilti warrants that the tool supplied is free of defects in material and workmanship. This warranty is valid so long as the tool is operated and handled correctly, cleaned and serviced properly and in accordance with the Hilti Operating Instructions, all warranty claims are made within 12 months from the date of the sale (invoice date), and the technical system is maintained. This means that only original Hilti consumables, components and spare parts may be used in the tool. This warranty provides the free-of-charge repair or replacement of defective parts only. Parts requiring repair or replacement as a result of normal wear and tear are not covered by this warranty.

**Under no circumstances will Hilti be obligated for direct, indirect, incidental or consequential dam-**

**ages, losses or expenses in connection with, or by reason of, the use of, or inability to use the tool for any purpose. Hilti specifically excludes the implied warranties of merchantability and fitness for a particular purpose.**

For repair or replacement, send tool and/or related parts immediately upon discovery of the defect to the address of the local Hilti marketing organization provided.

This constitutes Hilti's entire obligation with regard to warranty and supersedes all prior or contemporaneous comments and oral or written agreements concerning warranties.

